

Specifications:

PHYSICAL

Weight: Pump unit—175 lbs., Organic fuel tank—110 lbs.
Dimensions (WxDxH inches): Pump unit—42x24x75; Organic fuel tank—67x24x58
Capacity (US gallons) - Organic fuel tank: 250; E-Fuel100 holding tank: 50
Embedded communications: 802.11b/g, GSM (optional), Satellite (optional)
Visual alert features: 3 banks of 9 LED's (Red, Green, Blue) status activated
Audible alert feature: 65 dB alarm at 3.3 KHz
Safety/mechanical: Key insertion required for fuel pump operation
Color LCD touch screen for system status, operation, control and maintenance

OPERATING

Temperature: -20° F (-29° C) to 120° F (49° C)
Output potential each 7 day cycle: up to 70 US gallons (280 gallons using Enhanced Feedstock)
Water consumption: 0-4 US gallons per gallon of E-Fuel100 produced
Waste output: water and respective feedstock residue less the alcohol
Power consumption: Standard Feedstock approx. 3 KWh/gal E-Fuel100; Enhanced Feedstock approx. 1KWh/gal E-Fuel100 produced
Automatic fire suppression system: ABC dry chemical

REQUIREMENTS

Power: 220-250V, 5-0-60Hz, 20 amp dedicated breaker
Water supply, min 30 psi, 10 gallons per minute
Level installation pad and drain
Subscription to the E-Fuel Global Network (monthly fee may apply)
E-Fuel Global Network access 24x7 (Internet Wi-Fi, data cell or satellite)

Warranty: 2 year limited, on-site. Extended warranties available.
Life expectancy: 10-15 years
Certifications pending: CE, CSA, UL

Note: Specifications are subject to change without notice.

Part Numbers:
MFC200-001 MicroFueller closet, MFT200-001 Organic Fuel Tank with fermentation feature,
MFT200-005 Organic Fuel Tank without fermentation capability.



15466 Los Gatos Blvd., #109-37
Los Gatos, CA 95032

Email: sales@efuel100.com

www.microfueller.com

AUTHORIZED DISTRIBUTOR



Rev. 04-11a

EFUEL MICRO FUELER

EARTH'S FIRST HOME ETHANOL SYSTEM

Data Sheet 200 Series



E-FUEL CORPORATION
WWW.MICROFUELER.COM

- **Portable, Reliable, Sustainable**
- **Up to 70 gallons of E-Fuel100™ organic fuel per week (280 gallons with Enhanced Feedstock)**
- **Fuel your vehicles, generate your own electricity and get off the grid**

Introducing E-Fuel's **MicroFueller™ 200 Series**, earth's first home organic fuel processing system. Designed with the consumer in mind, the MicroFueller looks and operates like your typical corner gas station pump. Installation is no more complicated than a washing machine since it only requires water, electricity and a drain.

The MicroFueller consists of 2 main components: (1) the distillation/pumping unit and (2) the Organic Fuel (feedstock) Tank. Up to four feedstock tanks may be connected to each pumping unit to achieve high volume continuous E-Fuel100 production.



The Organic Fuel Tank holds organic waste (feedstock) for processing by the MicroFueller. Typical feedstock consists of waste identified and aggregated by your E-Fuel distributor. On an as needed basis, your distributor delivers feedstock to your MicroFueller which in turn produces E-Fuel100 ethanol. Enhanced feedstock may be used to increase daily E-Fuel100 production. Enhanced feedstock has been pre-processed by your distributor to increase the alcohol content up to 50%. Standard feedstock typically contains 15% alcohol.

As part of the MicroFueller total system solution, every MicroFueller subscribes to the E-Fuel Global Network (EGN) for a nominal monthly fee. The EGN monitors vital signs of your MicroFueller 24x7 and alerts the appropriate parties using email based upon pre-set conditions. As a user, all you need to be concerned with is pumping the E-Fuel100. The EGN bills monthly for the processing of organic waste by the MicroFueller at the agreed upon rate established between you and your servicing distributor. Monitored information is available to you, your distributor and E-Fuel through the MicroFueller Dashboard. Simply login at www.microfueller.com to view the Dashboard. When viewing the Dashboard, both real time and historical data are available.

MicroFuel—
internal view of
the distillation
column and
pumping unit

Legend:

HE = Heat exchanger
AD = Analog to digital converter
DA = Digital to analog converter
CPU = Central Processing Unit
LCD = Liquid Crystal Display

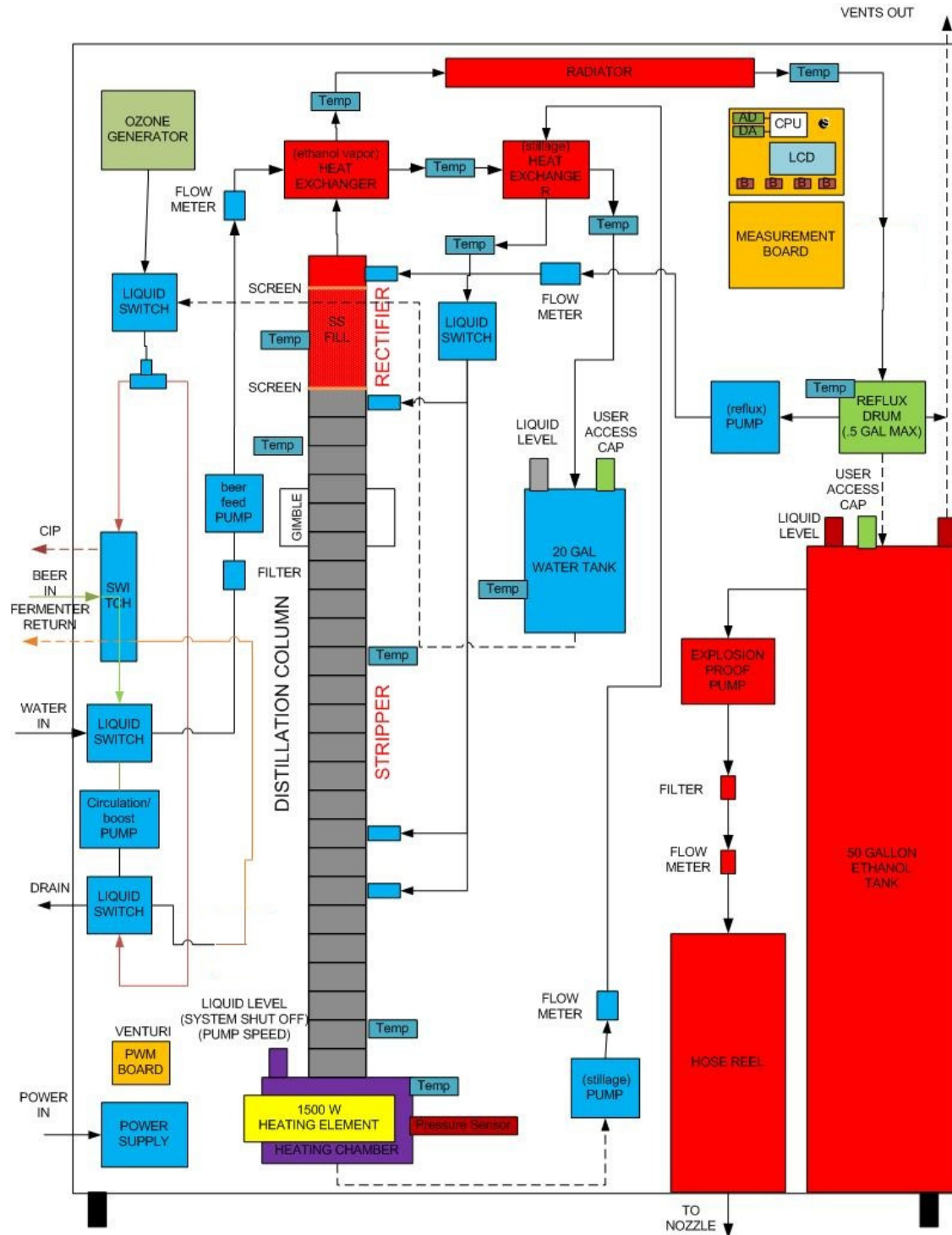
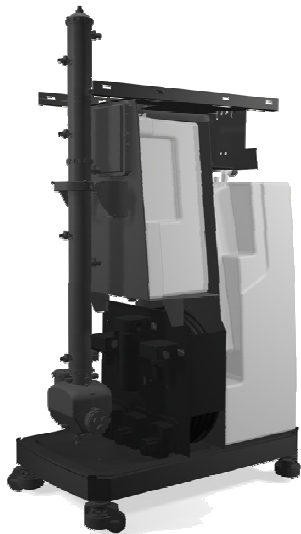

TO NOZZLE